



# Selecting Nozzles for Low Pressure Ground Sprayers

Ronald T. Noyes  
Extension Agricultural Engineer

H. Willard Downs  
Extension Agricultural Engineer

John B. Solie  
Research Agricultural Engineer

Richard W. Whitney  
Research Agricultural Engineer

Nozzle selection is one of the most important decisions to be made related to pesticide applications. The type of nozzle used determines not only the amount of spray applied to the target area, but also the uniformity of the applied spray, the coverage obtained on the sprayed surfaces, and the amount of drift that can occur. Each nozzle type has specific characteristics and capabilities designed for use under certain application conditions. The types which are commonly used for ground application of agricultural pesticides (and some liquid fertilizers) are the regular flat-fan, the even flat-fan, the flooding flat-fan, and the cone nozzle.

## Nozzle Types

**Regular flat-fan nozzles** are used for most broadcast spraying of herbicides and certain insecticides when foliar penetration and coverage are not required. These nozzles produce a flat, oval spray pattern with tapered edges (Figure 1). They are available in spray-fan angles of 65, 73, 80, and 110 degrees and are usually spaced 20 inches apart on the boom with boom heights of 10 to 23 inches above the ground. The boom heights recommended for various nozzle spray angles are shown below:

### Boom Height Above Ground

Spray Angles (degrees)	20-inch spacing (inches)
65	21-23
73	20-22
80	17-19
110	10-12

The normal recommended operating pressure for regular flat-fan nozzles is 15 to 30 psi. At these pressures, this nozzle type will produce medium to coarse drops that are not as susceptible to drift as the finer drops produced at pressures of 40 psi or greater. Regular, flat-fan nozzles are also recommended for some foliar applied herbicides, such as paraquat, at pressures of 40 to 60 psi. These high pressures will generate finer drops for maximum coverage on the plant

Oklahoma Cooperative Extension Fact Sheets are also available on our website at:  
<http://www.osuextra.com>

surface and good penetration through heavy residue. At these higher pressures, the possibility of drift increases significantly so appropriate precautions must be taken to minimize its effects. (See OSU Extension Fact Sheet F-1203 for drift reduction guidelines.)

The outer edges of the spray patterns of these nozzles have tapered or reduced volumes, so adjacent patterns along the boom must overlap in order to obtain uniform coverage. The most effective pattern is achieved when this overlap is 30 to 50 percent of the nozzle spacing (Figure 2). Because of their ability to produce a very uniform pattern when correctly overlapped, the regular flat-fan nozzle is generally the best choice for the broadcast application of herbicides.

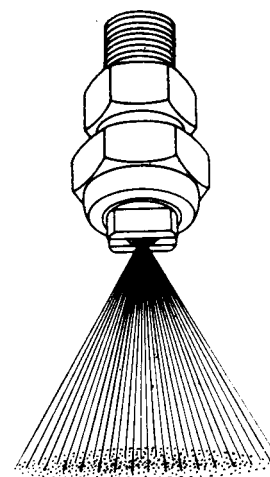

Figure 1. Regular Flat-Fan.

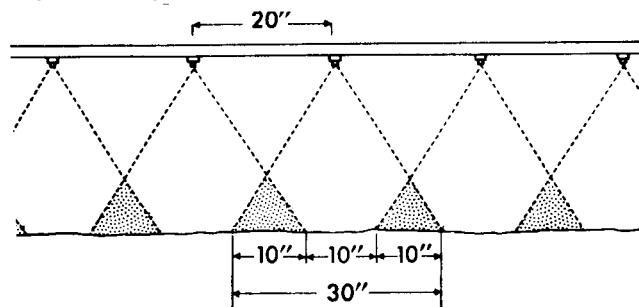

Figure 2. Regular Flat-Fan Nozzle - The width of the deposited spray pattern should be 50 percent larger than the nozzle spacing.

The LP or “Low-pressure” Flat-Fan Nozzles develop a normal fan angle and distribution pattern at spray pressures from 10 to 25 psi. Operating at a lower pressure results in larger drops and less drift than the regular flat-fan nozzle designed to operate at pressures of 15 to 30 psi.

**Even Flat-Fan Nozzles** apply uniform coverage across the entire width of the spray pattern (Figure 3). This type of nozzle is used for banding chemicals over the row. The recommended operating pressure for even flat-fan nozzles is between 15 to 30 psi. The width of the band produced is determined by nozzle height. The band widths produced for various nozzle heights are shown below:

Nozzle Height		
Band Width (inches)	80-degree (inches)	95-degree (inches)
8	5	4
10	6	5
12	7	6
14	8	7

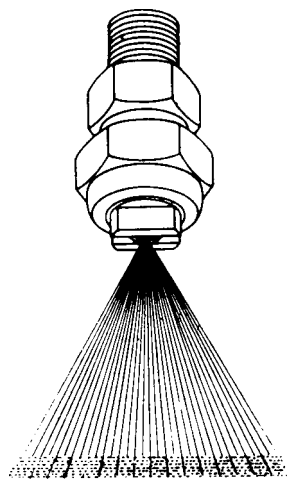

Figure 3. Even Flat-Fan.

**Flooding Flat-Fan Nozzles** produce a wide-angle, flat fan type pattern, and are commonly used for applying herbicides, mixtures of herbicides, and liquid fertilizers (Figure 4). The nozzle spacing on the boom for applying herbicides is generally 40 inches. These nozzles should be operated within a pressure range of 10 to 25 psi for maximum effectiveness and drift control. Changes in pressure will effect the width of the spray pattern more with this type of nozzle than with regular flat-fan nozzles. Also, the distribution pattern is usually not as uniform as that of a regular flat-fan tip. The most effective pattern is achieved when the nozzle is mounted at a height and angle to obtain at least double coverage or 100 percent overlap (Figure 5). Flooding nozzles can be mounted to spray straight down, straight back, or at an angle in-between. The most uniform coverage is obtained when the nozzle spray pattern is oriented at about a 45 degree horizontal angle (Figure 6-C).

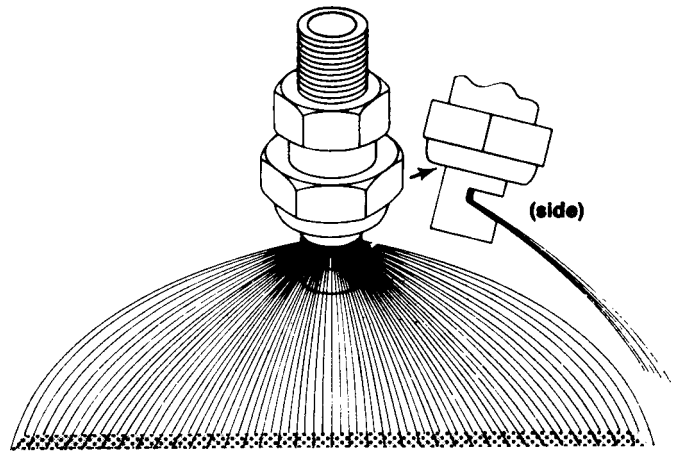

Figure 4. Flooding Flat-Fan.

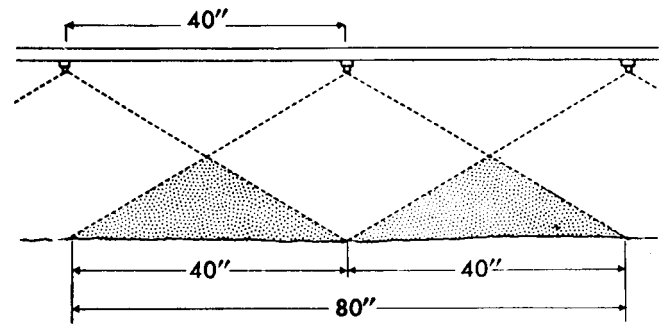

Figure 5. Flooding Flat-Fan Nozzle - The width of the deposited spray pattern should be two times the nozzle spacing.

The flooding flat-fan nozzles are the best choice for applying a liquid fertilizer or a liquid fertilizer-herbicide mixture. They are also effective when applying straight herbicides where drift is a problem. However, their pattern is not as uniform as a regular flat-fan nozzle, so they are less desirable for use when precise uniform coverage is required.

**Cone Nozzles** are used primarily when plant foliage penetration is essential for effective insect or disease control, and when drift is not a major concern of spraying fungicides or insecticides. At pressures of 40 to 80 psi, these nozzles produce small droplets that penetrate plant canopies and cover the underside of the leaves more effectively than any other nozzle type. However, because of the small droplets produced and high operating pressures, these nozzles produce patterns which are very susceptible to drift and **should not be used with any pesticide for which drift can cause problems.** They are very difficult to arrange along a boom for uniform distribution, and are not generally recommended for broadcasting herbicides.

The two common styles of cone nozzles available are solid-cone and hollow-cone. Solid-cone nozzles produce a cone-shaped pattern with a uniform distribution of chemical throughout the pattern. Hollow-cone nozzles produce a cone-

shaped pattern with the spray concentrated in a ring around the outer edge of the pattern (Figure 7).

Two special types of cone nozzles are Whirljet (Spraying Systems) and Raindrop (Delavan). Whirljet nozzles produce a hollow cone pattern with a fan angle of up to 140 degrees and are used primarily for herbicide incorporation.

The recommended pressure range is 5 to 20 psi. Raindrop nozzles have been designed to produce large droplets in a hollow-cone pattern at pressures of 20 to 60 psi. The two types of Raindrop nozzles are the "RA" and "RD." The RA nozzle (a whirl-chamber nozzle with the Raindrop cap) is used for herbicide incorporation and the RD Raindrop nozzle for foliar spraying. When used for broadcast application, these nozzles should be rotated 30 to 45 degrees from the horizontal to obtain the most uniform distribution.

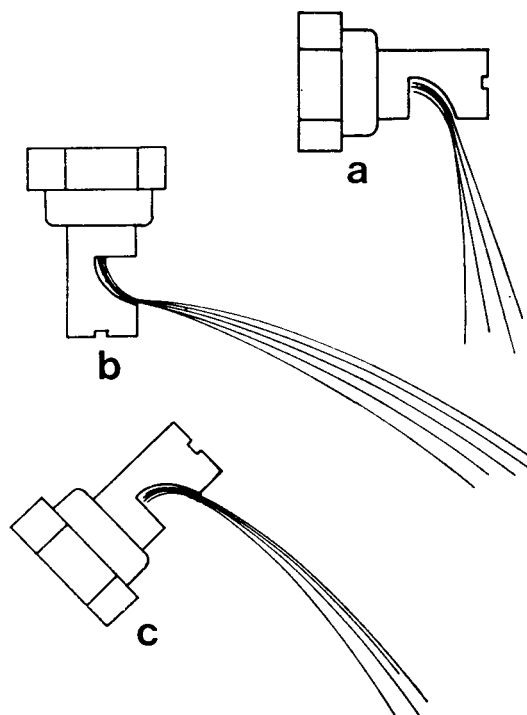

Figure 6. Flooding Flat-Fan Nozzle Operating Positions.

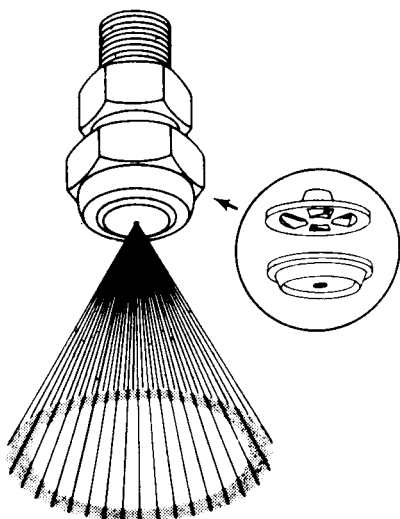

Figure 7. Hollow Cone

## Nozzle Materials

Nozzle tips are available in a wide variety of materials, including hardened, stainless steel, stainless steel, nylon, ceramic, and brass. Hardened, stainless steel is the most wear resistant material, but is also the most expensive. Stainless steel tips have excellent wear resistance with either corrosive or abrasive materials. Ceramic tips have greater wear life than the stainless nozzles but are brittle and subject to fracture. Composite nylon bodies with stainless steel or ceramic orifice inserts are available as a less expensive, long wear option.

Nylon tips are very resistance to corrosion and abrasion; however, they are subject to swelling when exposed to some solvents. Brass tips are the most common, but wear rapidly when used with abrasive materials such as wettable powders. They are also easily corroded by some liquid fertilizers. Brass tips are only recommended when used on sprayers with very low annual use. For sprayers which have more extensive use, stainless steel or nylon tips are more economical and a better buy because of their longer wear life. Figure 8 shows the relative wear rates of a regular flat-fan nozzle constructed of several alternate materials when used with a wettable powder formulation.

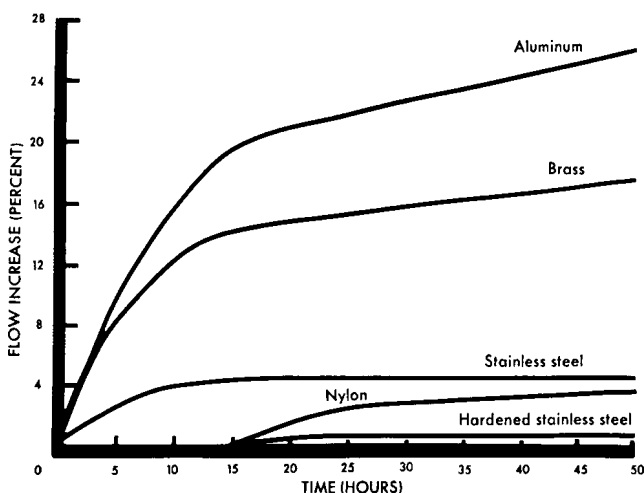

Figure 8. Wear Rates of Various Materials (regular flat-fan nozzle).

## Selecting Nozzle Tip Sizes for Desired Capacity

The best method for choosing the correct nozzle tip size is to calculate the gallons per minute (gpm) of nozzle output required, and then select a nozzle tip size that will provide this flow rate within the recommended pressure range. Do not rely on the "gallons per acre" rating which some manufacturers give their nozzles as means of selecting nozzle tip size. This rating is correct only for standard conditions (usually 30 psi, 4 mph, and 20-inch nozzle spacings). The gallons-per acre rating is useless with any variation from the standard. Use the steps described below to select the proper nozzle tip size.

The correct nozzle tip size will depend upon:

- (1) Application rate in gallons per acre (gpa),
- (2) Ground speed (mph),
- (3) Effective spray width of each nozzle (w)

**1. Determine “gpa”.** First determine the required application rate in gallons per acre (gpa). The application rate consists of the gallons of carrier (water, fertilizer, etc.) plus the required pesticide applied per treated acre. The best guides for this decision are the recommended ranges listed on the label, the recommendation of a chemical dealer or county agricultural educator, and experience with that particular chemical.

**2. Determine “mph”** Select an appropriate ground speed in miles per hour (mph) for the field to be sprayed. Experience is the best guide here. Generally, speeds between 3 to 8 mph are considered appropriate for low pressure ground sprayers, depending upon field conditions.

Do not rely on speedometers as an accurate measure of ground speed, especially on older tractors or trucks. Wheel slippage and variation in tire sizes can result in speedometer errors of 30 percent or more. For information on techniques for measuring ground speed, see OSU Extension Facts 1216, “Calibrating a Low-Pressure Ground Sprayer.”

**3. Determine “w”** Determine the effective sprayed width per nozzle (w) in inches.

For broadcast spraying, w = nozzle spacing, for band spraying, w = band width, for row-crop application, using drop pipes or directed spraying, w = row spacing (or band width)/ number of nozzles per row (or band).

**4. Determine Tip Size** Once the application rate, ground speed, and spray width per nozzle have been determined, the flow rate required for each nozzle in gallons per minute (gpm) can be determined by using a nozzle catalog, tables or the following equation:

$$GPM = \frac{gpa \times mph \times w}{5,940}$$

The constant, 5,940, is used to convert gallons per acre, miles per hour, and width in inches to gallons per minutes. The use of 6,000 instead of 5,940 will make the calculation easier and result in an error of only one percent.

Example: A herbicide is to be broadcast at 15 gpa at a speed of 7 mph, using flooding flat-fan nozzles spaced 40 inches apart on the boom. What size nozzle tip should be selected?

The required flow rate for each nozzle is as follows:

$$GPM = \frac{gpa \times mph \times w}{5,940}$$

$$GPM = \frac{15 \times 7 \times 40}{5,940}$$

$$GPM = \frac{4,200}{5,940} = 0.71$$

The nozzle selected must have a flow rate of 0.71 gpm when operated within the recommended pressure range of a flooding flat-fan nozzle (8 to 20 psi). By checking nozzle catalogs, one will find a number of different brands of flooding

flat-fan nozzles which will provide this flow rate. For example, the Spraying Systems TKS and Delavan DS nozzles have a rated output of 0.71 GPM at 20 psi. Either of these nozzles can be purchased for this application.

An alternate procedure is to select the nozzle based on catalog performance data, like the data in Figures 9 and 10. At 15 gpa and 7 mph, a TKS must be operated at 20 psi while a DS at 20 psi or a D6 at 13 psi could be selected.

**Figure 9. Performance Data for a Spraying System Flooding Type Nozzle.**

<i>Broadcast Application</i>				
<i>Nozzles: Flood Jet</i>	<i>Min psi 8</i>	<i>Max psi 20</i>		
<i>Water at 8.33 lb/gal</i>	<i>Tested psi range - 3 to 60</i>			
<i>15 GPA Swath-20ft</i>	<i>6 nozzle(s)</i>	<i>40-inch spacing</i>		
	—Ground speed (mph)—			
	5	6	7	8
<i>Orifice</i>	<i>Psi Req'd: [Boom height (in)]</i>			
TK4	15:[26]			
TK5	10:[25]	14:[22]	20:[19]	
TK7.5			8:[33]	11:[30]

**Figure 10. Performance Data for a Delavan Flooding Type Nozzle.**

<i>Broadcast Application</i>				
<i>Nozzles: D Flooding</i>	<i>Min psi 8</i>	<i>Max psi 20</i>		
<i>Water at 8.33 Lb/gal</i>	<i>Tested psi range - 10 to 40</i>			
<i>15 GPASwath - 20 ft6 nozzle(s)</i>	<i>40-inch spacing</i>			
	—Ground speed (mph)—			
	5	6	7	8
<i>Orifice</i>	<i>Psi Req'd:</i>			
D4	15			
D5	10	14	20	
D6		10	13	18
D7.5				11

**For Additional Information**

For additional information and fact sheets on sprayer components, sprayer calibration and chemical recommendation for various cropping systems, visit or call the OSU Extension Center in your county.

- Companion OSU Extension Facts are:**  
 1203, “Reducing Drift from Ground sprayers”  
 1216, “Calibrating a Low-Pressure Ground Sprayer”  
 1217, “The Low-Pressure Ground Sprayer”  
 1218, “Pumps for Low-Pressure Ground Sprayers”

Acknowledgement: Original manuscript prepared by Joseph F. Gerling, former Extension Agricultural Engineer.

Oklahoma State University, in compliance with Title VI and VII of the Civil Rights Act of 1964, Executive Order 11246 as amended, Title IX of the Education Amendments of 1972, Americans with Disabilities Act of 1990, and other federal laws and regulations, does not discriminate on the basis of race, color, national origin, sex, age, religion, disability, or status as a veteran in any of its policies, practices or procedures. This includes but is not limited to admissions, employment, financial aid, and educational services.

Issued in furtherance of Cooperative Extension work, acts of May 8 and June 30, 1914, in cooperation with the U.S. Department of Agriculture, Samuel E. Curl, Director of Cooperative Extension Service, Oklahoma State University, Stillwater, Oklahoma. This publication is printed and issued by Oklahoma State University as authorized by the Dean of the Division of Agricultural Sciences and Natural Resources and has been prepared and distributed at a cost of 20 cents per copy. 0703